

### Specification

Nominal Voltage	2V	
Nominal Capacity(10hrs rate)	1500.0AH	
Dimension	Length	403 ± 3mm(15.87 inches)
	Width	354 ± 3mm(13.94 inches)
	Container Height	339 ± 3mm(13.35 inches)
	Total Height (with Terminal)	349 ± 3mm(13.74 inches)
	Approx Weight	Approx 98.5 Kg (217.2lbs)
Design Float Life	20 years at 25°C(77°F)	
Container Material	ABS	
Rated Capacity	1605.0AH/80.3A	(20hr, 1.80V/cell, 25°C/77°F)
	1500.0AH/150.0A	(10hr, 1.80V/cell, 25°C/77°F)
	1305.0AH/261.0A	( 5hr, 1.75V/cell, 25°C/77°F)
	1170.0AH/390.0A	( 3hr, 1.75V/cell, 25°C/77°F)
	930.0AH/930.0A	( 1hr, 1.60V/cell, 25°C/77°F)
Max. Discharge Current	12000A (5s)	
Internal Resistance	Approx 0.35mΩ	
Operating Temp. Range	Discharge :	-15~50°C (5~120°F)
	Charge :	0~40°C (5~104°F)
	Storage :	-15~40°C (5~104°F)
Nominal Operating Temp. Range	25 ± 3°C (77 ± 5°F)	
Cycle Use	Initial Charging Current less than 450.0A. Voltage 2.4V~2.5V at 25°C(77°F)Temp. Coefficient -5mV/°C	
	Standby Use No limit on Initial Charging Current Voltage 2.25V~2.3V at 25°C(77°F)Temp. Coefficient -3mV/°C	
Capacity affected by Temperature	40°C (104°F)	103%
	25°C ( 77°F)	100%
	0°C ( 32°F)	86%
Self Discharge	≤1.5% per month RUZET TPA series batteries may be stored for up to 6 months at 25°C(77°F) and then a freshening charge is required.	

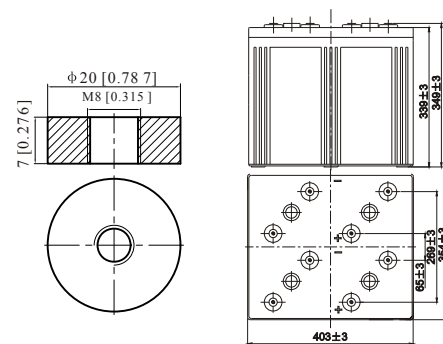

### Applications

- UPS and EPS
- Emergency light
- Railway signal and aircraft signal system
- Marine and power stations Alarm and security system
- Electronic apparatus and equipment
- Communication power supply, DC power supply

### Constant Current Discharge (Amperes) at 25°C (77°F)

F.V/Time	10 min	15 min	20 min	30 min	45 min	1h	2h	3h	4h	5h	6h	8h	10h	20h
1.85V/cell	1755.0	1476.0	1309.5	1086.0	838.0	717.0	464.3	349.1	285.9	240.6	210.8	169.1	145.4	77.6
1.80V/cell	\	1657.4	1447.8	1179.5	904.0	756.8	499.1	375.0	303.9	255.0	223.3	177.9	150.0	80.3
1.75V/cell	\	1868.1	1600.0	1281.8	986.0	825.0	519.0	390.0	314.4	261.0	230.3	183.9	154.0	82.3
1.70V/cell	\	\	1766.1	1399.4	1062.0	873.0	546.8	410.5	328.5	276.0	241.4	191.6	159.9	84.4
1.65V/cell	\	\	1878.9	1476.8	1124.0	903.0	566.9	427.0	341.5	284.7	249.8	198.1	164.4	87.0
1.60V/cell	\	\	\	1575.8	1168.0	930.0	581.3	438.0	349.1	291.6	255.0	201.6	167.9	88.4

### Constant Power Discharge (Watts) at 25°C (77°F)

F.V/Time	10 min	15 min	20 min	30 min	45 min	1h	2h	3h	4h	5h	6h	8h	10h	20h
1.85V/cell	3276.9	2783.7	2494.6	2091.6	1627.6	1397.4	910.9	687.4	564.8	476.4	418.5	337.3	290.6	155.2
1.80V/cell	\	3084.3	2717.9	2237.4	1742.2	1467.2	972.6	734.3	597.2	502.7	441.7	353.8	299.4	160.3
1.75V/cell	\	3434.0	2975.2	2411.4	1882.3	1592.1	1007.8	760.7	615.7	512.8	454.2	364.8	307.1	164.2
1.70V/cell	\	\	3259.7	2618.3	2019.9	1679.4	1059.5	799.2	642.0	541.4	475.2	379.8	318.6	168.3
1.65V/cell	\	\	3442.1	2740.6	2118.7	1724.7	1092.1	827.8	664.9	556.5	490.3	391.7	327.1	173.3
1.60V/cell	\	\	\	2904.2	2190.0	1767.0	1114.5	845.3	677.5	568.2	499.0	397.7	333.4	175.8