

## Specification

Nominal Voltage	2V	
Nominal Capacity(10hrs rate)	100.0AH	
Dimension	Length	170±2mm(6.69 inches)
	Width	72±2mm(2.83 inches)
	Container Height	205±2mm(8.07 inches)
	Total Height (with Terminal)	212±2mm(8.35 inches)
Approx Weight	Approx 6.0 Kg (13.2 lbs)	
Design Float Life	20 years at 25°C(77°F)	
Container Material	ABS	
Rated Capacity	107.0 AH/5.35A	(20hr, 1.80V/cell, 25°C/77°F)
	100.0 AH/10.0A	(10hr, 1.80V/cell, 25°C/77°F)
	87.0 AH/17.4A	( 5hr, 1.75V/cell, 25°C/77°F)
	78.0 AH/26.0A	( 3hr, 1.75V/cell, 25°C/77°F)
	62.0 AH/62.0A	( 1hr, 1.60V/cell, 25°C/77°F)
Max. Discharge Current	800A (5s)	
Internal Resistance	Approx 1.4mΩ	
Operating Temp. Range	Discharge :	-15~50°C (5~120°F)
	Charge :	0~40°C (5~104°F)
	Storage :	-15~40°C (5~104°F)
Nominal Operating Temp. Range	25±3°C (77±5°F)	
Cycle Use	Initial Charging Current less than 30.0A. Voltage	
	2.4V~2.5V at 25°C(77°F)Temp. Coefficient -5mV/°C	
Standby Use	No limit on Initial Charging Current Voltage	
	2.25V~2.3V at 25°C(77°F)Temp. Coefficient -3mV/°C	
Capacity affected by Temperature	40°C (104°F)	103%
	25°C ( 77°F)	100%
	0°C ( 32°F)	86%
Self Discharge	≤1.5% per month	
	RUZET TPA series batteries may be stored for up to 6 months at 25°C(77°F) and then a freshening charge is required.	

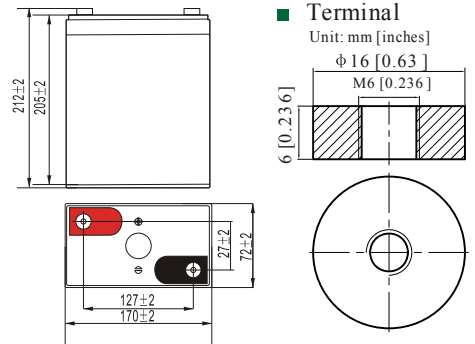

## Applications

- UPS and EPS
- Emergency light
- Railway signal and aircraft signal system
- Marine and power stations Alarm and security system
- Electronic apparatus and equipment
- Communication power supply, DC power supply

### Constant Current Discharge (Amperes) at 25°C (77°F)

F.V/Time	10 min	15 min	20 min	30 min	45 min	1h	2h	3h	4h	5h	6h	8h	10h	20h
1.85V/cell	117.0	98.4	87.3	72.4	55.9	47.8	31.0	23.3	19.1	16.0	14.1	11.3	9.69	5.17
1.80V/cell	133.9	110.5	96.5	78.6	60.3	50.5	33.3	25.0	20.3	17.0	14.9	11.9	10.0	5.35
1.75V/cell	152.1	124.5	106.7	85.5	65.7	55.0	34.6	26.0	21.0	17.4	15.4	12.3	10.3	5.49
1.70V/cell	171.7	138.2	117.7	93.3	70.8	58.2	36.5	27.4	21.9	18.4	16.1	12.8	10.7	5.63
1.65V/cell	184.4	147.9	125.3	98.5	74.9	60.2	37.8	28.5	22.8	19.0	16.7	13.2	11.0	5.80
1.60V/cell	202.9	162.0	136.1	105.1	77.9	62.0	38.8	29.2	23.3	19.4	17.0	13.4	11.2	5.89

### Constant Power Discharge (Watts) at 25°C (77°F)

F.V/Time	10 min	15 min	20 min	30 min	45 min	1h	2h	3h	4h	5h	6h	8h	10h	20h
1.85V/cell	218.5	185.6	166.3	139.4	108.5	93.2	60.7	45.8	37.7	31.8	27.9	22.5	19.4	10.3
1.80V/cell	247.1	205.6	181.2	149.2	116.1	97.8	64.8	49.0	39.8	33.5	29.4	23.6	20.0	10.7
1.75V/cell	276.2	228.9	198.3	160.8	125.5	106.1	67.2	50.7	41.0	34.2	30.3	24.3	20.5	10.9
1.70V/cell	304.9	250.5	217.3	174.6	134.7	112.0	70.6	53.3	42.8	36.1	31.7	25.3	21.2	11.2
1.65V/cell	324.5	266.2	229.5	182.7	141.2	115.0	72.8	55.2	44.3	37.1	32.7	26.1	21.8	11.6
1.60V/cell	348.9	286.8	246.6	193.6	146.0	117.8	74.3	56.4	45.2	37.9	33.3	26.5	22.2	11.7